

Drawer Slide Mounting Tool Instructions

10 Hughes Suite A-105, Irvine, California 92618 U.S.A.
 Toll Free: (800)-763-8390 Local Phone: 949-215-9746 Fax: 800-679-8390
 Web: www.RokHardware.com E-mail: support@rokhardware.com

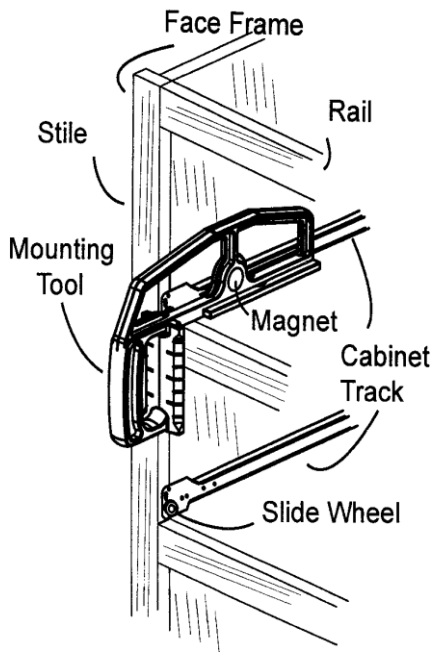

The Drawer Slide Mounting Tool is designed to easily install metallic drawer slides. Metal drawer slides are very popular because they work well, add a professional touch, and are economical. However, without a mounting tool the job is tedious because of all the measuring and marking involved. Our new mounting tool eliminates the need for measuring and marking because it uses the intersection of the stile and rail as a reference point so that each cabinet track is mounted accurately. It also works with frameless cabinets.

The Drawer Slide Mounting Tool can be used to install the hardware from a number of manufacturers including Alfit, Amerock, BLUM, Hafele, Hettich and Liberty.

READ THEIR INSTRUCTIONS CAREFULLY

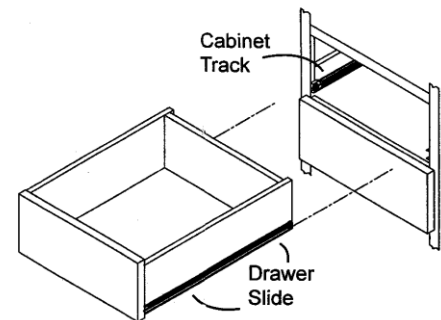
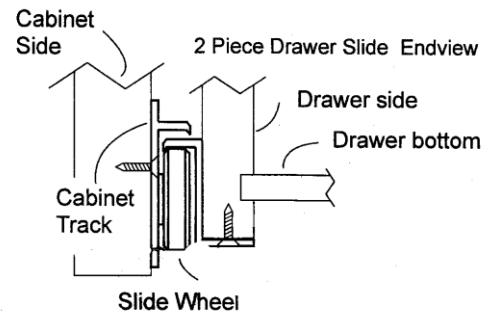
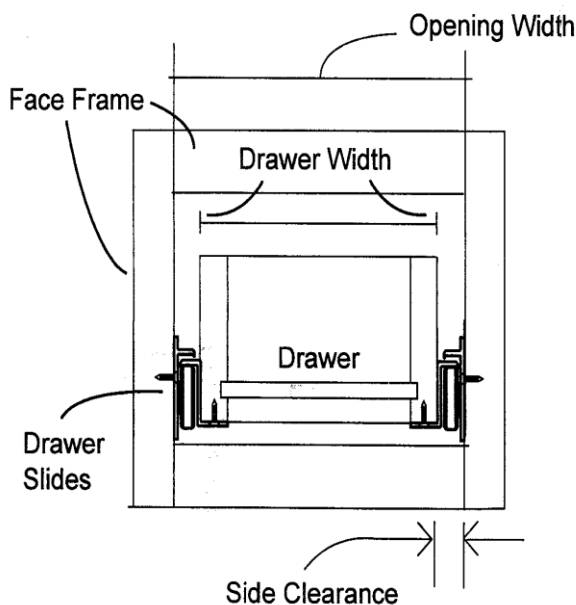

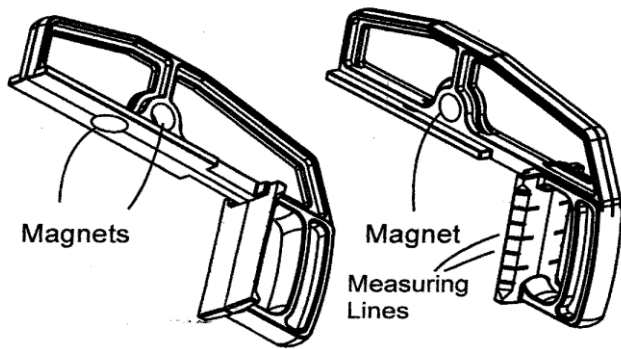

This tool's design employs magnets to hold the cabinet track in place. The new magnetic design improves the ease of use of this tool. There is a magnet on each side of the Drawer Slide Mounting Tool so one tool is used for mounting the track to the cabinet on either side of the drawer.

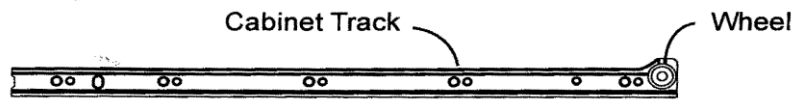

The side mounting drawer slides are made of two parts. The part that is mounted to the cabinet is called the cabinet track. It is U shaped with a flattened end to which a wheel is attached

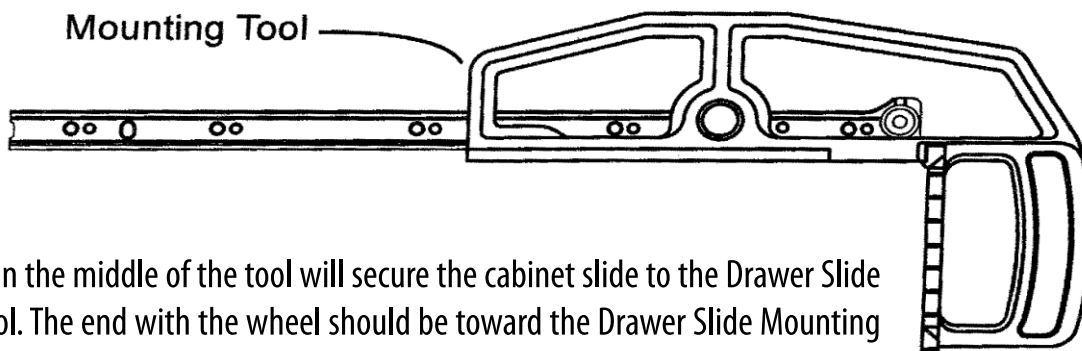

The magnet in the middle of the tool will secure the cabinet slide to the Drawer Slide Mounting Tool. The end with the wheel should be toward the Drawer Slide Mounting Tool with the slide parallel to the bottom of the Drawer Slide Mounting Tool. A clamp can be used to secure the mounting tool in place. The cabinet track typically has an oblong hole. Use this hole for securing the track to the side of the cabinet. Putting the screw in the middle of the oblong hole allows for a slight adjustment.

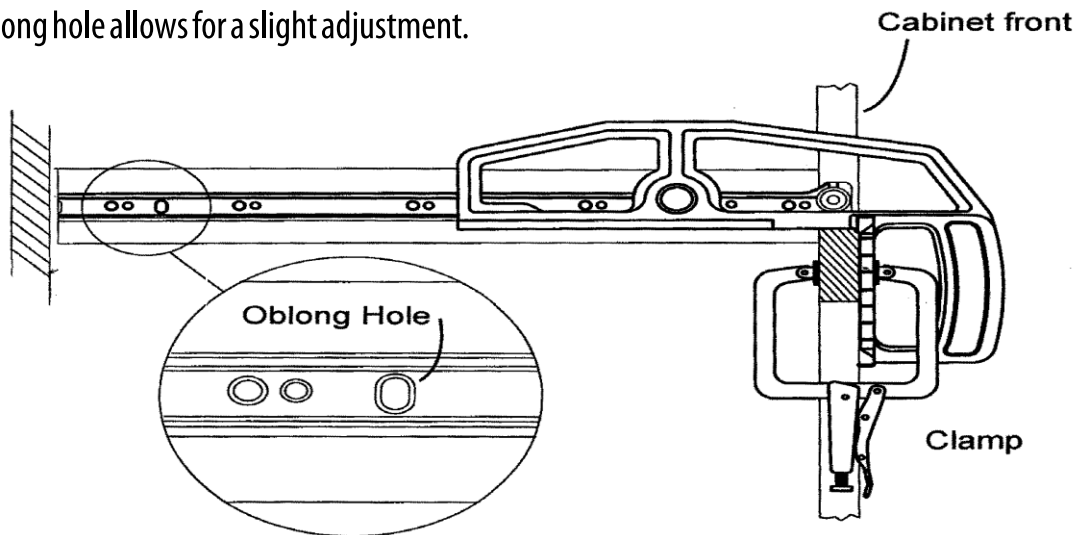

When building frameless cabinets or when the cabinet side is flush with the inside edge of the stile the cabinet track can be screwed to the inside of the cabinet as shown in the bottom left drawing.

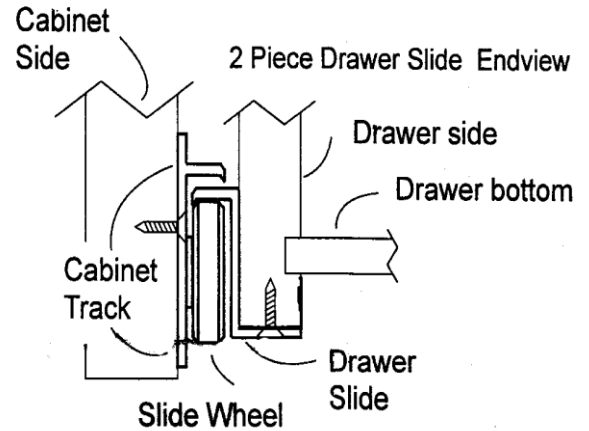
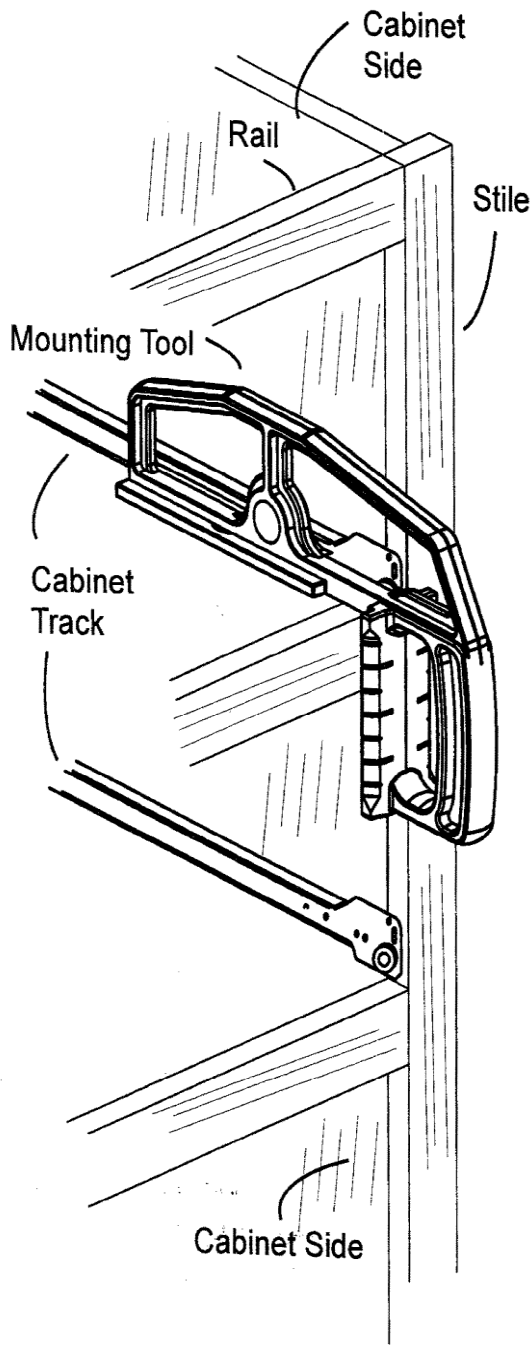

When there is a space between the edge of the stile and the cabinet side, a mechanism is needed to support the cabinet track. One option is to use a commercially available plastic rear cabinet track support as shown below

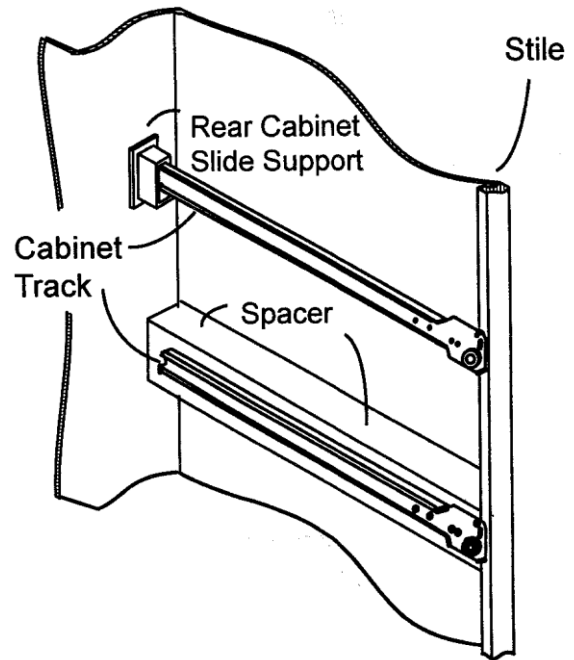

Another option is to use a wood spacer as shown above. The spacer is the width of the distance between the edge of the face frame and the side of the cabinet.

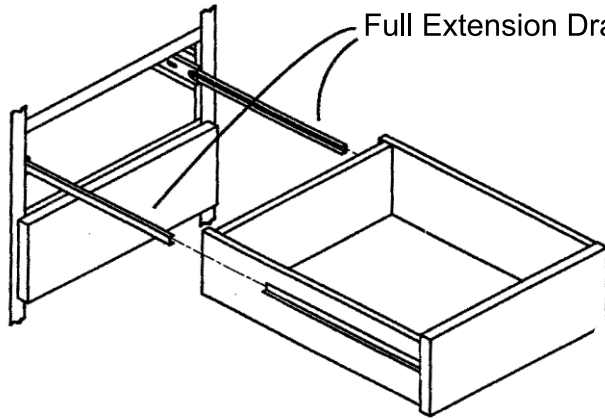

Full Extension Drawer Slides

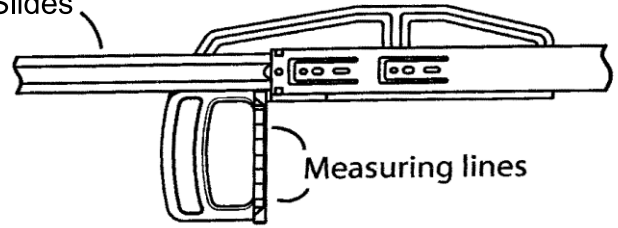

Measuring lines

Full extension drawer slides are designed to support a lot of weight and extend all of the way out of the cabinet. The Drawer Slide Mounting Tool is ideal for accurately positioning full extension drawer slides. The drawing on the left shows two options for clamping the full extension drawer slides to the face frame or the cabinet side

Full Extension Drawer Slides

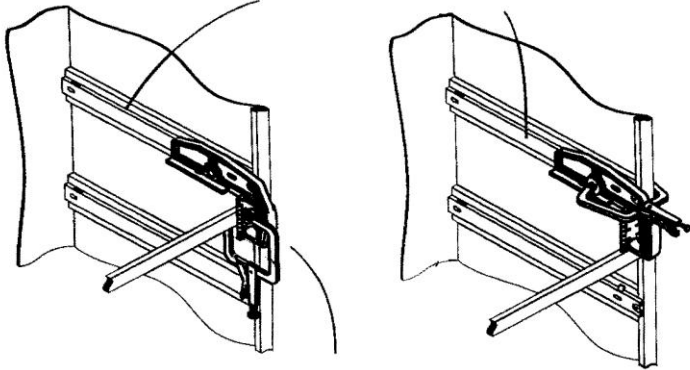

Drawer Slide Mounting Tool

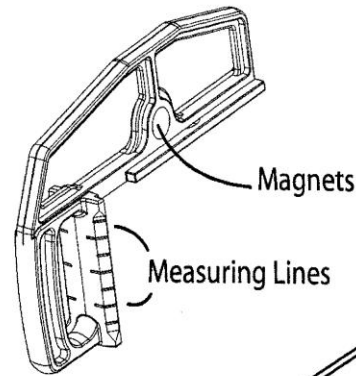

Magnets

Measuring Lines

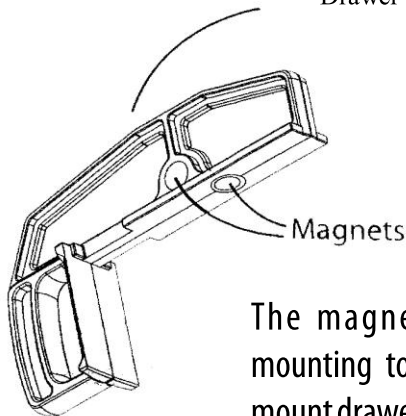

Magnets

The magnet on the bottom of the mounting tool is used to locate bottom mount drawer slide as shown on the right.

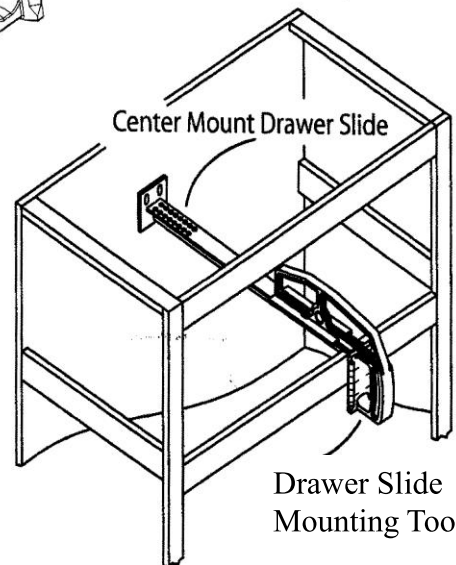

Center Mount Drawer Slide

Drawer Slide Mounting Tool



10 Hughes Suite A-105, Irvine, California 92618 U.S.A.
 Toll Free: (800)-763-8390 Local Phone: 949-215-9746 Fax: 800-679-8390
 Web: www.RokHardware.com E-mail: support@rokhardware.com